

System 46

RF/Microwave Switch System

32 Configurable Channels



Flexible Solutions in a Compact Package

The S46 Microwave Switch System is designed to simplify the automated switching needed to test a wide range of telecommunications products and devices. The S46 can control 32 relay contacts in a package as small as a 2U high (3.5 in) full-rack enclosure. A variety of standard S46 configurations are available, as well as fully custom systems with up to 32 channels for controlling microwave relays, programmable attenuators, and other components. Both standard and custom configurations

make it simple to select a system that meets the specifications of the testing application without the expense of unnecessary switches or other features. This "just what you need and no more" design philosophy allows S46 systems to provide outstanding price/performance value.

The enclosures used in standard S46 configurations can accommodate eight SPDT coaxial microwave relays and four multi-pole coaxial microwave relays. Any of these multi-pole relays can be one of the following relay types: SP3T, SP4T, SP5T, or SP6T. S46 switching systems can be used as multiplexers, matrices, independent relays, or a combination of configurations. To order a standard system, simply select the number of relays and their location on the front panel. As test requirements change, relays can be easily added to the system to create a new switch configuration.

Simple Operation

The S46 switch system's 32 control channels can be operated via the IEEE-488 interface bus with a minimal set of instructions. This small instruction set ensures the system can be set up and running quickly. Front panel LEDs indicate the status of all relay contacts continuously to allow the user to monitor system operation easily.

Excellent Microwave Switching Performance

Keithley's experience and partnerships with leading manufacturers in the microwave relay industry allow Keithley to offer the lowest insertion loss, VSWR, and crosstalk performance specifications available. Low-loss, semi-flexible RF cables are available as accessories to maximize signal integrity.

Maximum System Up-Time and Enhanced System Performance

The S46 controller automatically counts relay contact closures to allow equipment maintenance personnel to assess when the relays are nearing the end of their mechanical life. In this way, preventive maintenance can be performed in a timely way during scheduled shutdowns, avoiding unplanned shutdowns and the resulting loss of production time.

In addition to counting contact closures, the S46 has a portion of its memory available to store S-parameters or calibration constants for each relay contact or each pathway. If a specific performance parameter is critical, such as Voltage Standing Wave Ratio (VSWR) or insertion loss, the parameter can be stored in memory for use in trend analysis between scheduled maintenance shutdowns. Stored parameters can also be used for compensation to enhance accuracy during RF measurements.

ACCESSORIES AVAILABLE

S46-SMA-0.5	Low Loss, Semi-Flex SMA-SMA Cable Assembly, 0.152m (6 in)
S46-SMA-1	Low Loss, Semi-Flex SMA-SMA Cable Assembly, 0.305m (12 in)
S46-TW	SMA Cable Torque Wrench
S46-SPDT-KIT	SPDT Relay and Cable Assembly
S46-SP4T-KIT	SP4T Relay and Cable Assembly
S46-SP6T-KIT	SP6T Relay and Cable Assembly

- Compact RF/microwave switching system only 2U high
- Built-in contact closure counter to monitor switch cycles
- Standard configuration allows up to 32 channels of switching
- Simple control with built-in GPIB/IEEE-488 interface bus
- Channel characterization data storage

APPLICATIONS

- Cellular and cordless phones
- Specialized mobile radios
- Base stations
- Specialized antenna systems
- RF components, including RFICs
- Wireless peripherals, including Bluetooth devices
- Broadband wireless transceivers
- High speed digital communications, including SONET speeds 3Gbps and 10Gbps

1.888.KEITHLEY (U.S. only)

www.keithley.com

KEITHLEY

A GREATER MEASURE OF CONFIDENCE

Designed for test applications that require high quality RF/microwave signal routing

RF/MICROWAVE SWITCHING
AND MEASUREMENT

System 46

RF/Microwave Switch System

32 Configurable Channels

Examples of Standard System Switch Configurations

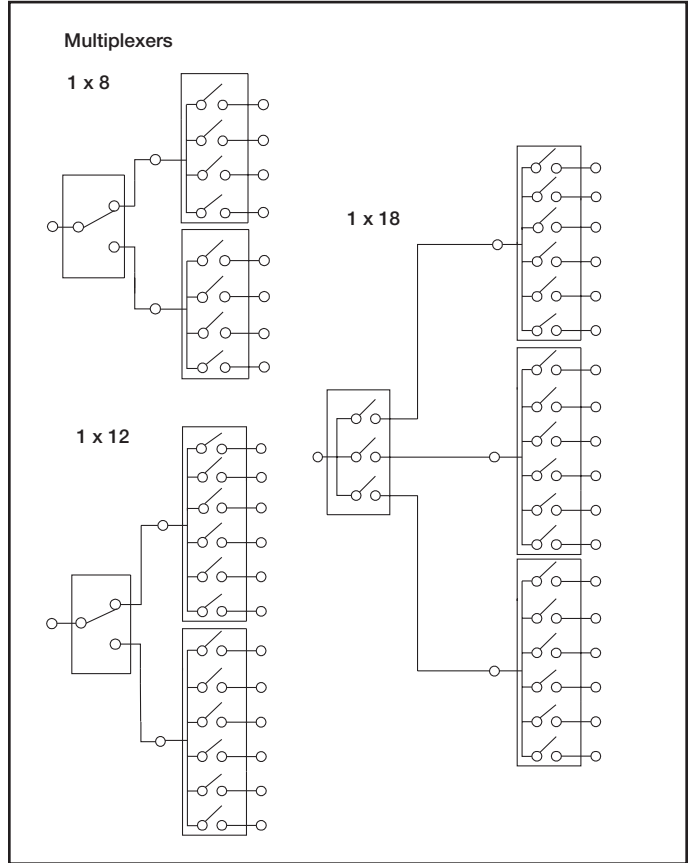
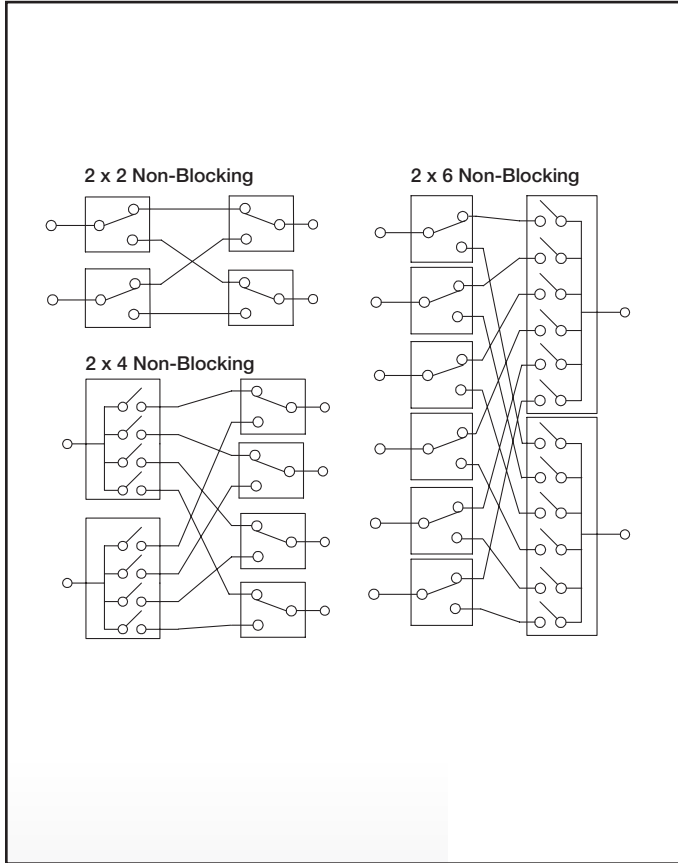

Typical Performance Data of a 1x12 Multiplexer

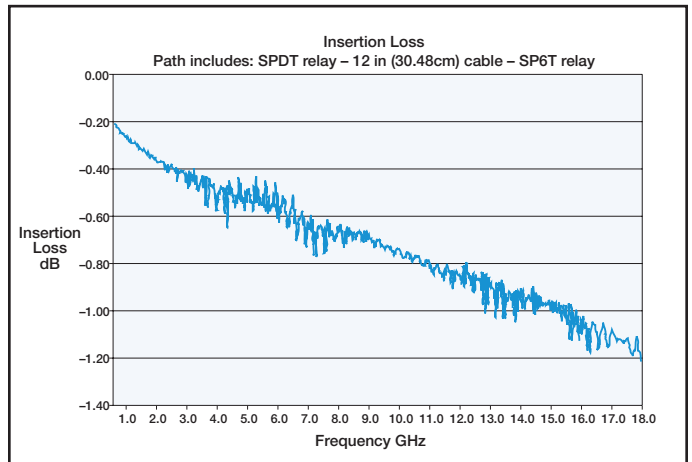
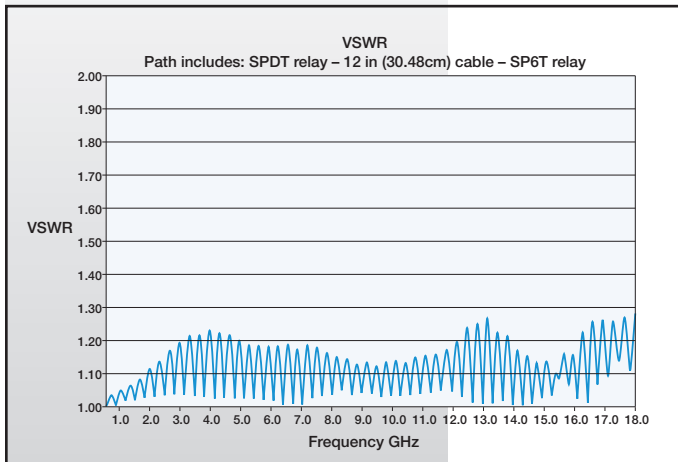

1.888.KEITHLEY (U.S. only)

www.keithley.com

KEITHLEY

A GREATER MEASURE OF CONFIDENCE

Designed for test applications that require high quality RF/microwave signal routing

RF/MICROWAVE SWITCHING
AND MEASUREMENT

System 46

RF/Microwave Switch System

32 Configurable Channels

ORDERING INFORMATION

Specifying Standard S46 Model Numbers

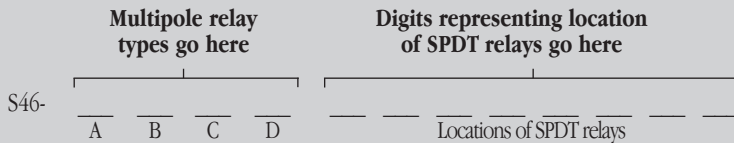
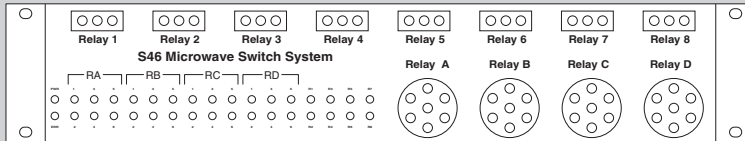

Multipole relay locations A - D: Enter a “3” for a SP3T relay, a “4” for an SP4T relay, a “5” for a SP5T relay, or a “6” for a SP6T relay in the required location. Enter a “0” in unused multi-pole locations. There must be digits in all four positions.

SPDT relay locations 1–8: Indicate the position number of all locations where an SPDT switch is required. Only locations used are required.

For example, here’s what model number S46-0604 356 would indicate:

- A SP6T relay in position “B”
- A SP4T relay in position “D”
- SPDT relays in positions 3, 5, and 6.

Accessories Supplied

Power cord, instruction manual, and rack mount kit.

S46 MICROWAVE SWITCH SYSTEM SPECIFICATIONS

MAXIMUM CONFIGURATION

- (8) – Terminated SPDT relays
- (4) – Terminated multi-pole relays (SP3T, SP4T, SP5T, SP6T)

RELAY SPECIFICATIONS

CONNECTOR TYPE: Female SMA connector.

CONTACT LIFE: 2 million cycles minimum.

VSWR:

- DC–6GHz: 1.25:1 max.
- 6–12GHz: 1.40:1 max.
- 12–18GHz: 1.50:1 max.

INSERTION LOSS:

- DC–6GHz: 0.2dB max.
- 6–12GHz: 0.4dB max.
- 12–18GHz: 0.5dB max.

ISOLATION:

- DC–6GHz: 70dB min.
- 6–12GHz: 60dB min.
- 12–18GHz: 60dB min.

ACTUATION TIME: SPDT: 20ms max. Multi-pole: 15ms max.

MAXIMUM COMMON MODE: 42V peak, any terminal to earth.

FREQUENCY RANGE: 0–18GHz.

GENERAL

CONTACT CLOSURE COUNTERS: 1 counter per channel, up to 10 million counts each, maintained in non-volatile memory.

NON-VOLATILE STORAGE: 32 separate locations; each location up to 68 bytes long, for user-definable channel and system parameters.

NUMBER OF RELAY CONTROL LINES: 32, each open collector driver capable of 300mA sink current (max.).

INTERFACE: GPIB (IEEE-488.2) and SCPI.

INDICATORS: Power, relay position status, and error LED.

POWER: 100–240VAC.

ENVIRONMENT: Operating: 0° to 40°C, up to 35°C < 80% RH.
Storage: –25° to 65°C.

EMC: Conforms to European Union Directive 89/336/EEC.

SAFETY: Conforms with European Union Directive 73/23/EEC.

DIMENSIONS: 89mm high × 485mm wide × 370mm. deep
(3.5" × 19" × 14.563").

SHIPPING WEIGHT: 13kg (28 lbs).

1.888.KEITHLEY (U.S. only)

www.keithley.com

KEITHLEY

A GREATER MEASURE OF CONFIDENCE